

introducing the Innotech

ProFill



Box Filling System

110V Source

PLC Controls

Modular Belting



TOUCH SCREEN
CONTROL INTERFACE

Designed for Low Volume Facilities
Dribble Gate for Accurate Fill
Flighted Conveyor for Boxes

INNOTECH
Process Equipment
Parts . Sales . Service . Manufacturing

INNOTECHPROCESSEQUIPMENT.COM



Solution Based Engineering
Superior Quality Manufacturing
Exceptional Customer Service



Specifications **ProFill**

Conveyor Feed

512LBS

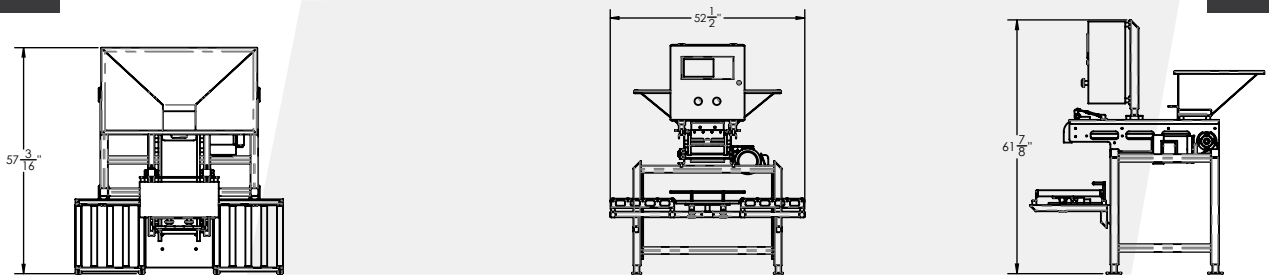

Vibratory Feed

695LBS

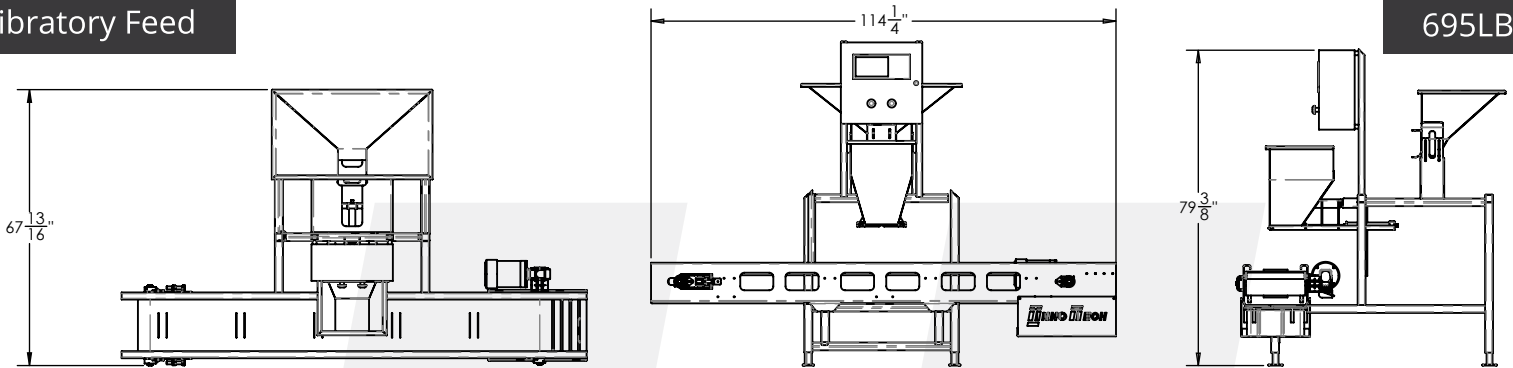

- 110v Source powers entire unit
- PLC driven controls
- Fast fill/slow fill with dribble gate for more accuracy
- Touch screen controls
- Modular belting or vibratory feeders
- Single or multiple heads
- Approximately 6000 lbs. per hour-per-head
- Adjustable weight configurations
- Left or right hand configurations
- Scale can be under box or weigh vessel
(weigh vessel used if different box sizes are desired)